

# GRP INSTALLATION INSTRUCTIONS

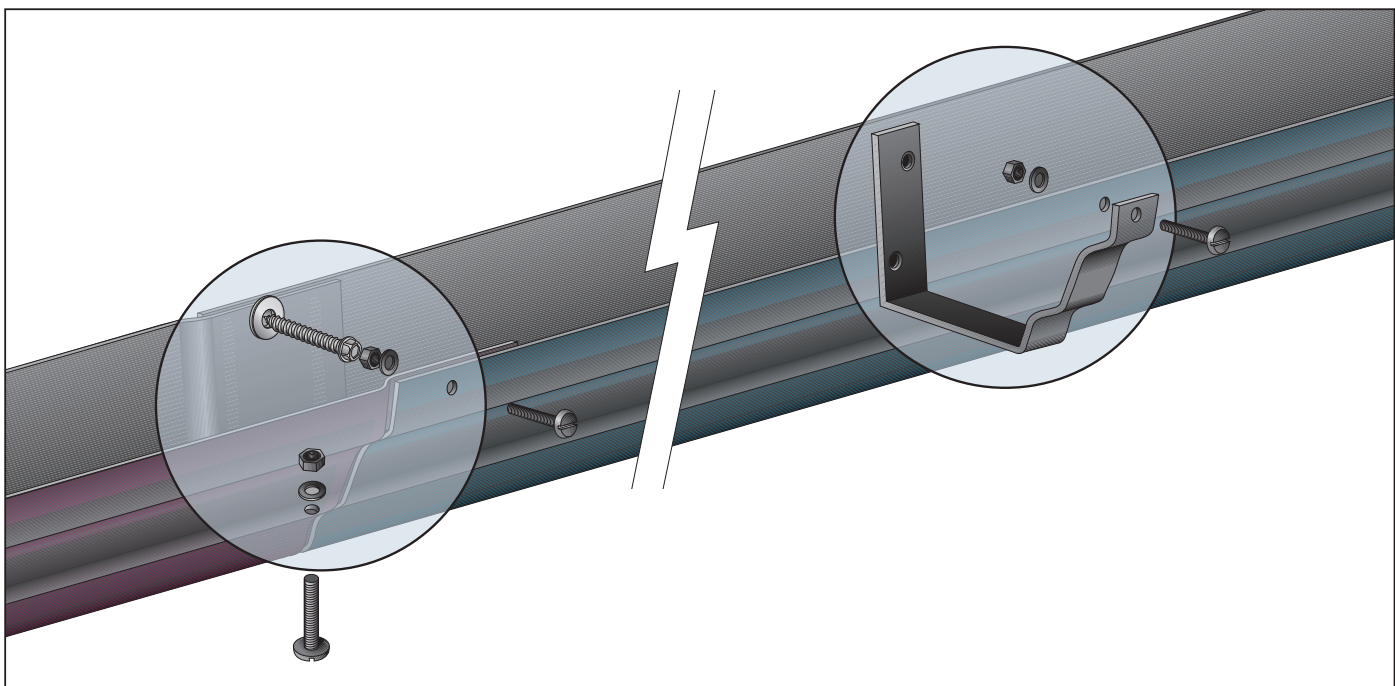
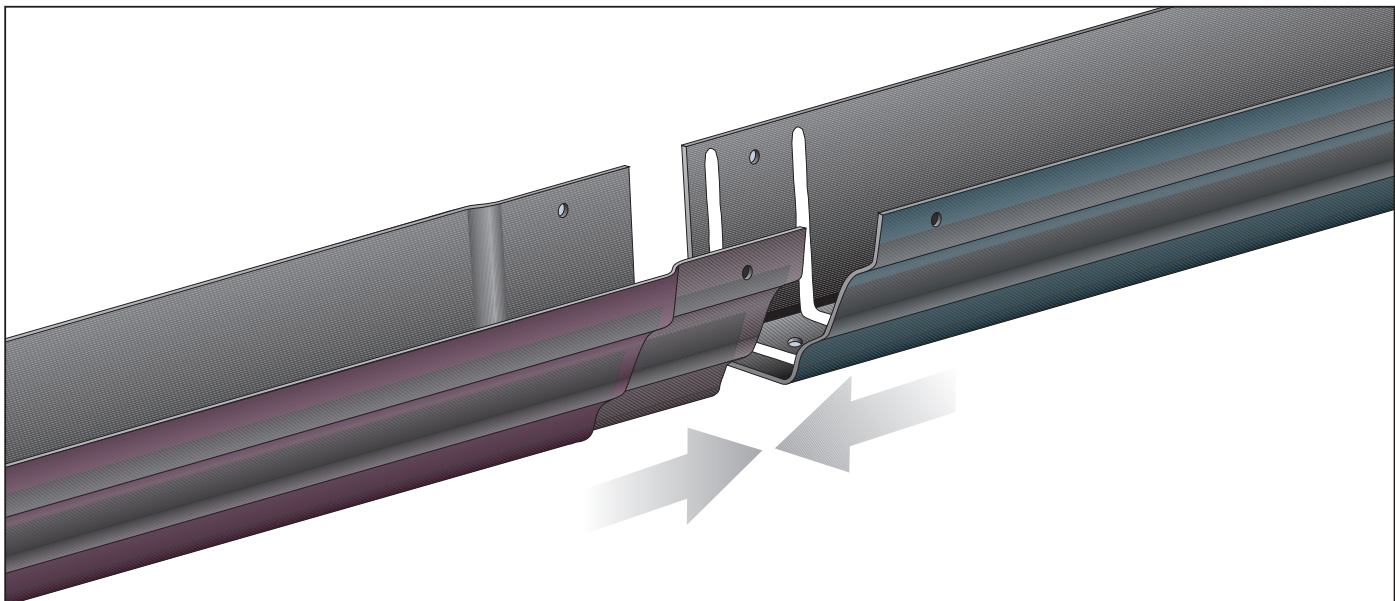

## GRP GUTTERS

1. Fix gutter brackets to give correct line and level (min. 2 no. brackets per length). Ensure fixings are adequate to obviate pull out.
2. Place gutter in position ensuring correct sit into brackets.
3. At joint, drill gutters through underside and also through top of front face to accept gutter bolts (holes to be 3mm oversize to allow for thermal movement).
4. Ensure gutter socket and spigots are dry, clean, dust and grease free prior to applying silicone sealant.
5. Apply 2 no. 6mm sealant beads between spigot and socket joint around bolt hole to ensure alignment of leading edges of gutter when joints are bolted together.
6. Bolt joints together through previously drilled holes, at the same time aligning front edges. Do not over tighten.
7. Drill back of gutter approx. 18mm from top at every joint and maximum 600mm centres. (Holes to be 3mm oversize to allow thermal movement).
8. Secure gutter through previously drilled holes in back, using a minimum 18mm OD washer between head of fixing and gutter. Do not over tighten and cause misalignment of gutter (use packers between back of gutter and wall if necessary). Ensure fixings are adequate to obviate pull out.
9. Secure gutter to bracket by bolting through hole provided at every alternate bracket.
10. Remove any surplus sealant from faces of gutter.

The Yeoman Rainguard Gutter should be fixed wherever possible using the profile gutter brackets. This principle applies even when existing corbels are used.

Where it is not possible to use brackets and the gutter is sat only on corbels, the gutters can be manufactured with extra strengthening, however the corbels should project far enough to support the full underside of the gutter.